

White Paper

RPA Redundant Parallel Architecture

Contents

Page:

1.	Introduction	2
2.	Important Characteristics	2
3.	Evolution of Reliability	3
4.	Apparent or real redundancy	4
5.	RPA Redundant Parallel Architecture	6

Preface

"White Paper" a document discussing key advantages of GE UPS systems

These documents are created to support consulting engineers, end-customers, salesforce and all others that are looking for more information than available on the standard datasheets.

GE Industrial Systems and the author disclaim all responsibility subsequent to incorrect use of information or diagrams reproduced in this document and can not be held responsible for any error or oversights, or for consequence of using information, configuration and diagrams contained in this document.

This document is intended for informational purpose only.

This document shall not be copied or reproduced without written permission of GE Industrial Systems.

Document release

Release: March 2005

Author: Henk Mulder

Department: UPS Product Management

6595 Riazzino (Locarno) – Switzerland

Introduction

As automation continues in our society, dependency on electrical energy increases.

Today's power grid, was designed with applications such as a refrigerator or a light bulb in mind.

Whereas these applications could survive with an interruption of the supply for seconds, in today's 24x7 economy such disturbances may be disastrous.

Corporations and other organizations, large and small, are now automated in many ways.

Think of: entry control systems, building automation, datacenters, telecom equipment, PC/workstations etc.

All of this equipment becomes worthless without a reliable energy supply and can even jeopardize the continuity of the business.

The classic UPS (Uninterruptible Power Supply) is an essential part of a total reliable system which mitigates the increased risk of dependency of electrical power.

Important Characteristics

Before discussing the technicalities of various concepts to design high-reliability power supply systems, some key characteristics need to be defined.

There are 4 important factors that are critical for end-users.

Reliability – The probability that a system will perform its specified function in a specified amount of time.

Another way to express reliability is: the mean time that elapses between two consecutive failures on one unit, or MTBF (Mean Time Between Failures).

For an end-user, reliability means less or no failures.

Availability – The probability that a system will perform its specified function at a certain time.

This can also be defined as: $Availability = \frac{MTBF}{(MTBF + MTTR)}$, where MTTR is Mean Time To Repair.

For an end user this means: I do not want failures, but if there is a breakdown, how fast can you fix it?

Sometimes the MTBF is perceived to be one of the most important characteristic of a UPS system.

It is, however, important to note that MTTR is as least as important as MTBF.

Example: What is preferable? A car that breaks down twice a year but can be fixed in one day, or a car that breaks down once a year which takes 1 week to be fixed.

On the operational side there are two other important factors for end-users:

Flexibility – There is no formal definition to give here.

Once a system is installed the question is how long its function will be required.

In today's fast changing environment this is hard to predict.

End-users struggle with questions like, will my company grow, and if yes at which location.

We can also define flexibility here as protection of investment.

Cost of Operation – One important aspect here is the efficiency of a UPS system.

In case of a low efficiency the end user will notice that on the energy bill.

Also, UPS equipment with low efficiency generates more heat which will increase the energy consumption of air conditioners.

End-users should not be seduced to sacrifice Reliability and Availability for the sake of cost of operation.

It is like taking an insurance policy with low premiums that does not pay out in case of an event.

Four end user CTQ's (Critical To Quality):

Reliability
Availability
Flexibility
Cost of Operation

Evolution of Reliability

The static UPS (Fig. 1) was invented to improve the reliability of the supply of electrical energy. The utility AC voltage is converted into DC voltage by the rectifier. Batteries are connected to the DC voltage that function as an emergency supply. The DC voltage is converted back in to AC voltage by the inverter, which supplies the load with clean and reliable power. In case there is an interruption in the utility voltage, the batteries will seamlessly take over. The output voltage will not be disturbed.

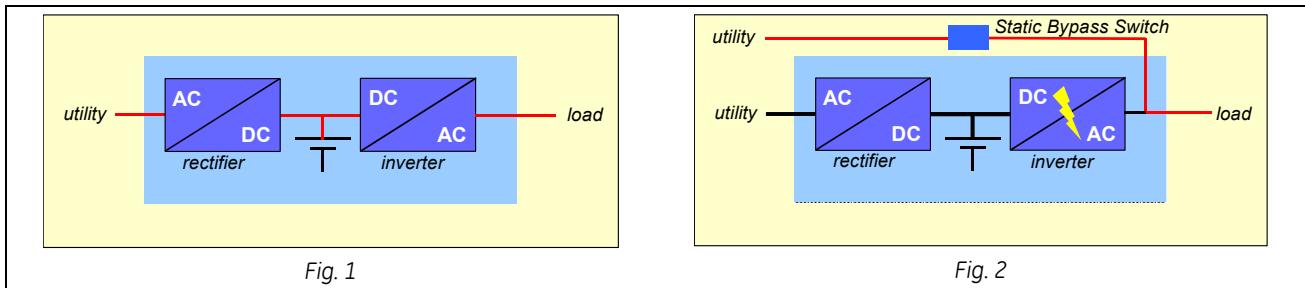

The solution above was found to be suitable. However, there was a need to increase the reliability of such a system. At that point the static bypass was introduced by GE, in 1965. In the event that the rectifier or the inverter would fail the UPS would transfer the load from inverter to bypass. In that way the load was supplied by the utility. During that time the UPS could be repaired. During supply via bypass the load is not protected. To enhance the reliability the so-called Hot Standby or cascade configuration was introduced. It basically means that the output of one UPS is used to supply the static bypass of another UPS, as shown in Fig. 3.

In case the primary UPS (1) fails it transfers the load to bypass, which is supplied by a secondary UPS (2). In this way a certain redundancy is created. The advantage is that this is a simple solution and it can be done with any UPS (even those supplied by different vendors) together. However, there are also some drawbacks. First of all, the secondary unit is always running on zero load in normal condition. The load is not shared, and one UPS has an accelerated lifetime compared to the other. If there is a failure in the primary UPS it will need to transfer to bypass.

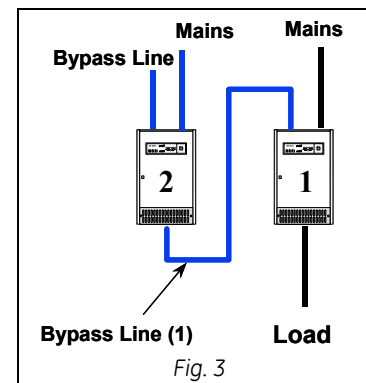

At the same time the secondary UPS will see a step-load. Both the commutation to bypass on one UPS and the step load on the other can lead to a (temporary) unstable supply to the load. The overload capacity is limited to the overload capacity of 1 unit. In case of an overload the primary unit will transfer to bypass first, and then there will be a second transfer to bypass at the secondary unit. In the hot standby configuration some points are scored for reliability, however there is no possibility to repair the UPS without sacrificing redundancy. The system cannot be expanded, which limits flexibility. One unit running idle creates additional energy loss therefore increasing the cost of operation.

Below the scores for the hot standby configuration are summarized:

Scores for different configurations	
CTQ:	Hot Standby
Reliability	Neutral
Availability	Poor
Flexibility	Neutral
Cost of Operation	Poor

Apparent or real redundancy

As shown previously, hot standby was not fulfilling the need of end-users completely.

As a solution the industry came up with parallel UPS systems (Fig. 4).

With this configuration some of the drawbacks of the hot standby configuration are eliminated.

First of all there is load sharing, which means the load is equally distributed over all UPS units in the system.

In case one UPS fails, the other UPS is still there to supply the load (provided the rating of one UPS is sufficient!).

There is no bypass transfer required in such a case.

If one unit fails it can be isolated from the system, repaired and re-introduced to the system without any interruption to the load. The system can be expanded by adding units.

Finally the total efficiency is better with respect to the hot stand by configuration, since there is no unit running idle.

As the overload capacity of one unit is 150% of nominal power the overload capacity of a redundant system is 300% of the nominal power of one UPS.

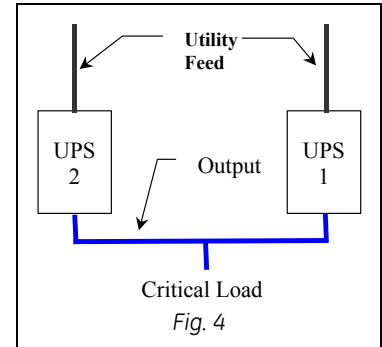

But what about the static bypass ?

In the industry we see 2 different bypass configurations in parallel UPS systems.

Centralized and Decentralized bypass (Fig. 5).

Some important differences have to be noted.

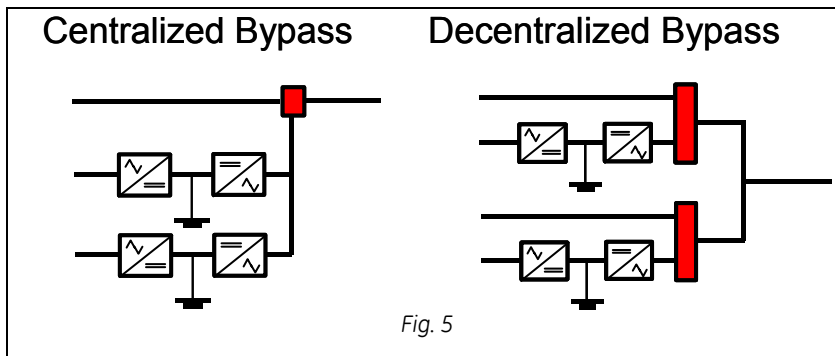

By paralleling UPS systems the intention is to create a redundant system.

By implementing a centralized bypass a single point of failure is introduced.

In case the (centralized) bypass module fails, the system fails.

So in terms of reliability this does not seem to be the best solution.

With respect to availability (MTTR) we see that the centralized bypass module cannot be repaired without transferring the load to an external bypass.

If the end-user wants to upgrade the system in the future, the centralized bypass needs to be replaced with a bigger one or should be oversized from the beginning to anticipate the future upgrade.

Also there is additional wiring and an additional cabinet required for a centralized bypass.

In case of a decentralized bypass one can see that redundancy is maintained, also for the bypass circuit.

In case of failure a complete unit is isolated from the system and can be repaired without transferring the load to bypass. Upgrades can be done by just adding another unit.

A system can even be split up to install the units somewhere else in different configurations.

A decentralized bypass offers great flexibility.

GE introduced the first decentralized bypass system in 1985.

Scores for different configurations			
CTQ:	Hot Standby	Parallel with centralized bypass	Parallel with decentralized bypass
Reliability	Neutral	Insufficient	Good
Availability	Poor	Insufficient	Good
Flexibility	Neutral	Poor	Good
Cost of Operation	Poor	Neutral	Neutral

Paralleling UPS systems is a complex technical process.

The different outputs of the UPS units need to be synchronized with high accuracy and the currents delivered by each UPS unit need to be equal.

In case a transfer to bypass is required, all units need to transfer to bypass (in case of decentralized bypass) in order to prevent UPS units to feed back to the mains.

To keep all these processes within specification intelligent control logic is required.

Also here different solutions can be found in the marketplace.

One of them is the master-slave configuration (Fig. 6).

In a parallel system one of the units is the master and controls the process.

In this case a single point of failure is introduced to the system and the system is not redundant anymore.

In case the master unit fails, the system fails and the supply to the load is interrupted or in the best case the system transfers the load to bypass.

Again, on bypass the load is not protected.

Another solution quite common in the industry is to have, in addition to the UPS units, a "central command" logic which controls the system.

The use of the word "central" disguises that here is also a single point of failure.

If the central control logic fails the systems fails or, again, at best transfers the load to bypass.

In both cases there is clearly a miss in redundancy and, as a consequence, in reliability

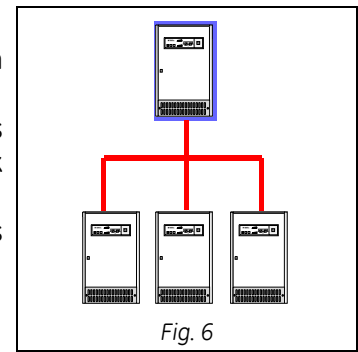

Often solutions are declared redundant, but seldom is the definition of redundancy included.

When is a parallel UPS system really redundant?

The answer is hard to define in one sentence.

One way to say it: there is more than one possibility for the system to perform the specified function.

In other words: the system can afford at least one single failure to maintain the specified performance.

For a parallel UPS system redundancy can be translated into the following:

- Fault tolerance** – In case there is one single failure the system will still perform it's specified function.
- Detection** – Detect which failure is present in which unit
- Isolation** – Isolate the unit that failed without any disturbance in the output of the system.
- Remediation** – Solve the problem on the unit that failed without transferring the load to bypass (repair).
- Redundancy Recovery** – Re-introduce the repaired unit into the system without any interruption in the output or transfer to bypass.

The table with can be extended and completed as follows:

<i>Scores for different configurations</i>				
<i>CTQ:</i>	<i>Hot Standby</i>	<i>Parallel with centralized bypass</i>	<i>Parallel with decentralized bypass</i>	<i>Master/Slave Central Control</i>
Reliability	Neutral	Insufficient	Good	Neutral
Availability	Poor	Insufficient	Good	Good
Flexibility	Neutral	Poor	Good	Good
Cost of Operation	Poor	Neutral	Neutral	Neutral

RPA Redundant Parallel Architecture

To overcome all drawbacks of different configurations GE has developed and further enhanced RPA (Redundant Parallel Architecture).

With RPA, up to 8 UPS units (Fig. 7) can be connected in parallel offering true redundancy.

The decentralized bypass increases the reliability and makes it possible to upgrade the system easily.

There is no central control logic, each unit in the system can be the logic leader.

This "dynamic democratic" process makes it possible that even if the logic leader fails, another unit will instantly become the logic leader.

The communication between the units flows via a redundant bus.

The redundant bus consists physically of 2 separate cables.

Even if one cable gets cut, the system continues to perform.

The fast communication bus ensures that the units stay synchronized with high precision.

The maximum phase difference is 0.03 ms (0.65 degrees).

This also offers high precision loadsharing and a "best in class" dynamic response to step loads.

This is a more stable solution compared to wireless solutions currently available in the market.

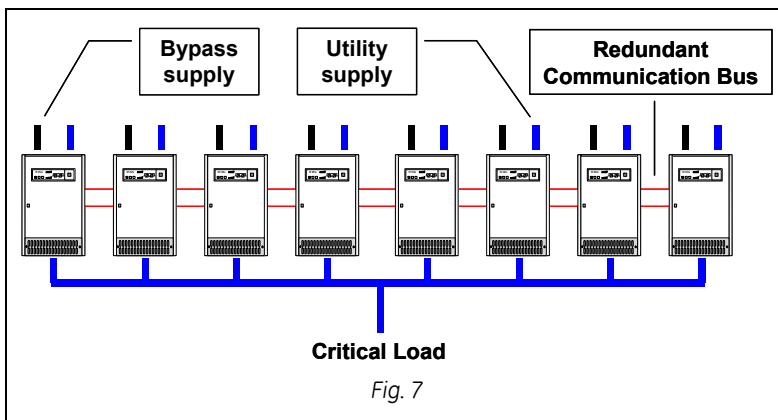

RPA overcomes all of the drawbacks of other configurations and is a true redundant system.

There are no mandatory, vendor specific output junction cabinets that can act as a single point of failure.

High reliability is reached through a decentralized bypass, no central control logic and a redundant communication bus.

In case of a failure a unit is isolated from the system, allowing safe repair

After repair the unit can seamlessly be re-introduced into the system, providing high availability.

RPA is a flexible configuration. Up to 8 units can be paralleled and due to the decentralized bypass units can be added and removed without restriction.

Ultimately that means protection of investment.

GE UPS units have a high efficiency for all load conditions - including at 50% load, which is the most common situation for redundant parallel systems (two units).

With GE's IEM Intelligent Energy Management software package the efficiency of the system can be further improved by adapting the system to the actual load condition and the required degree of redundancy.

Scores for different configurations					
CTQ:	Hot Standby	Parallel with centralized bypass	Parallel with decentralized bypass	Master/Slave or Central Control	RPA
Reliability	Neutral	Insufficient	Good	Neutral	Best-in-Class
Availability	Poor	Insufficient	Good	Good	Best-in-Class
Flexibility	Neutral	Poor	Good	Good	Best-in-Class
Cost of Operation	Poor	Neutral	Neutral	Neutral	Best-in-Class

RPA is the Best-in-Class system concept for reliable, flexible and cost-effective power supply systems for mission critical applications.