

GE Consumer & Industrial
Power Protection

Product Description

Digital Energy™ Uninterruptible Power Supply

LP 31 Series / 8 – 10 – 15 – 20 kVA

400 VAC CE / Series 1

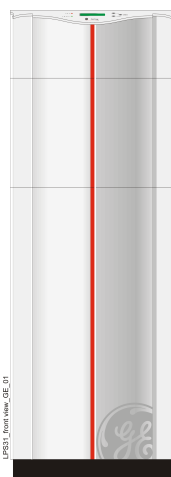

Manufactured by:

GE Consumer & Industrial SA
General Electric Company
CH – 6595 Riazzino (Locarno)
Switzerland
T +41 (0)91 / 850 51 51
F +41 (0)91 / 850 51 44
www.gedigitalenergy.com



GE imagination at work

CE



Model: **LP 31 Series / 8 – 10 – 15 - 20 kVA / Series 1**
 Date of issue: 01.10.2005
 File name: PRD_LPS_31E_8K0_20K_1GB_V021
 Revision: 2.1

Up-dating		
Revision	Concerns	Date
2.0	GE House-style	15.03.2005
2.1	GE Consumer & Industrial SA	01.10.2005

Table of contents

Page

1. INTRODUCTION	3
2. FUNCTIONAL EXPLANATION.....	3
2.1 Principles of Operation.....	3
2.2 Normal Conditions	4
2.3 Mains Failure	4
2.4 Bypass operation	5
3. EXTERNAL DESCRIPTION	6
3.1 Front and Rear Panel.....	6
3.2 The LCD screen.....	6
3.3 Alarm Conditions	7
4. STANDARD FEATURES	8
5. INTERFACING	9
5.1 ComConnect (RS232 Interface).....	9
5.2 Potential Free Contact Interface	10
5.3 SNMP Interface (optional)	10
6. OPTIONS.....	10
6.1 SNMP Interface Card.....	10
6.2 Alarm Boxes	10
6.3 Connectivity Products.....	10
6.4 Battery Extension Packs	10

COPYRIGHT © 2005 by GE Consumer & Industrial

Data subject to change without prior notice.

All brands and product names are Trademarks or Registered Trademarks of their respective owners.

Reproduction only upon written consent by GE.

1. INTRODUCTION

The **LP 31 Series / 8 – 10 – 15 – 20 kVA** UPS series is a compact, truly On-line 3-phase in 1-phase out system which incorporates the most advanced power electronics technology to provide exceptional protection for electrical equipment.

2. FUNCTIONAL EXPLANATION

2.1 Principles of Operation

The UPS stores electric energy in batteries housed in the unit.

This allows the system to supply output power even when the incoming mains power is cut off completely.

Energy is stored as Direct Current (DC), but input and output energy must be Alternating Current (AC) in sine wave form.

The UPS therefore contains an input converter (AC to DC) and an output converter (DC to AC) (Figure 1).

The **LP 31 Series / 8 – 10 – 15 – 20 kVA** UPS is a SECOND GENERATION On-line UPS with:

- battery not in line with the DC link, resulting in:
 - enhanced battery life;
 - optimal battery charging;
- full wave input converter with power factor correction;
- extremely wide input voltage and input frequency tolerance;
- output converter (inverter) using IGBT technology.

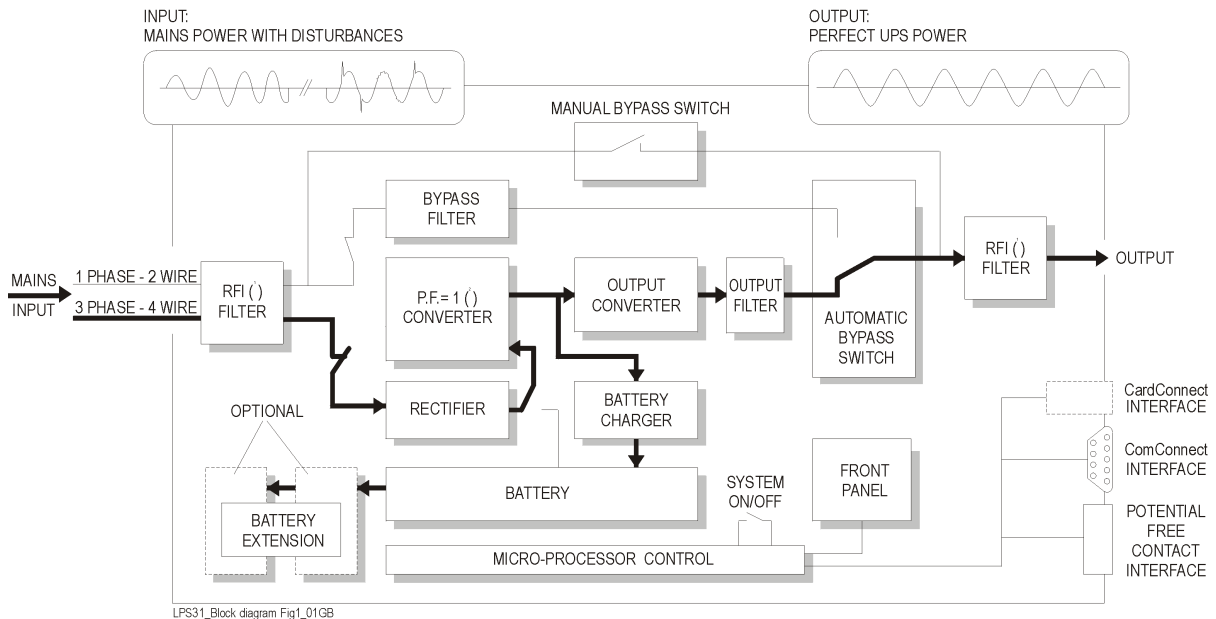

Figure 1 - Block diagram of the LP 31 Series / 8-10-15-20 kVA UPS, mains present

The UPS needs two separate mains:

One three phase + neutral input mains and a single phase bypass mains. The neutral is essential.

2.2 Normal Conditions

Under normal input conditions (see section 4.2) energy from the mains is channelled through the input converter, which supplies the output converter and, together with the battery charger, keeps the battery fully charged.

Surges and spikes are blocked completely at the input converter and very unstable mains can be supported.

The output converter synthesises a completely new AC output sine wave to supply the load (electrical equipment).

2.3 Mains Failure

In the event of a mains power failure (i.e. absent or outside tolerance) the output converter uses the energy reserve stored in the battery to continue to produce AC power, ensuring unbroken output

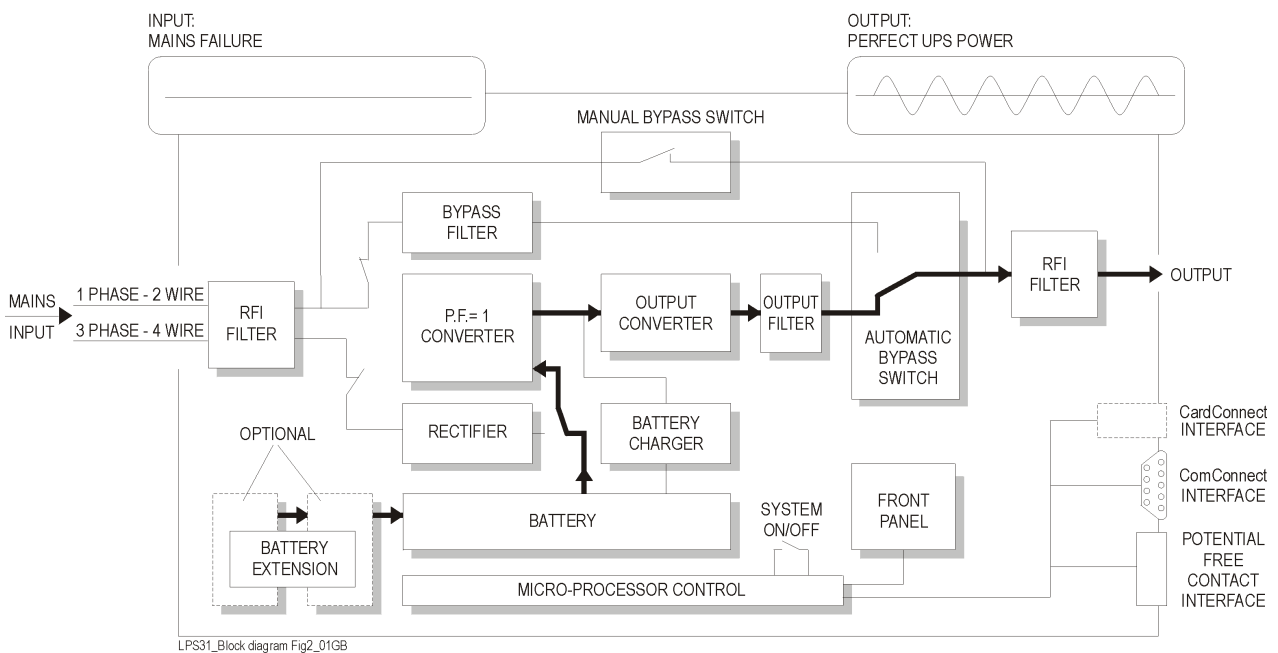

Figure 2 - Block diagram of the LP 31 Series / 8-10-15-20 kVA UPS, mains failure

No interruption or alteration will ever be noticed in the output power.

In the event of an extended mains failure, the output converter will stop when the battery energy has been used up.

At this point, the UPS is no longer able to power the connected equipment.

When the mains is re-established within tolerance, the output converter will be supplied again by the input converter and the batteries will be recharged, making them ready to support future power failures.

2.4 Bypass operation

The static switch provides transfer of the load to the line voltage without any interruption of the supply. The transfer is initiated by a signal from the output converter protection circuit in case of an overload, high temperature or output converter failure.

When the conditions return to normal the load is automatically transferred back to the output converter.

If the output converter is unable to deliver the demanded output power (overload, overtemperature) the bypass switch will automatically transfer the load to the mains.

If bypass operation is caused by an overload situation, the UPS will switch back to output converter if the load is reduced to less than 100%.

If bypass operation is caused by overtemperature, the unit will only switch back when the temperature has dropped below alarm level.

When the normal situation is restored, the load will be transferred back to the output converter.

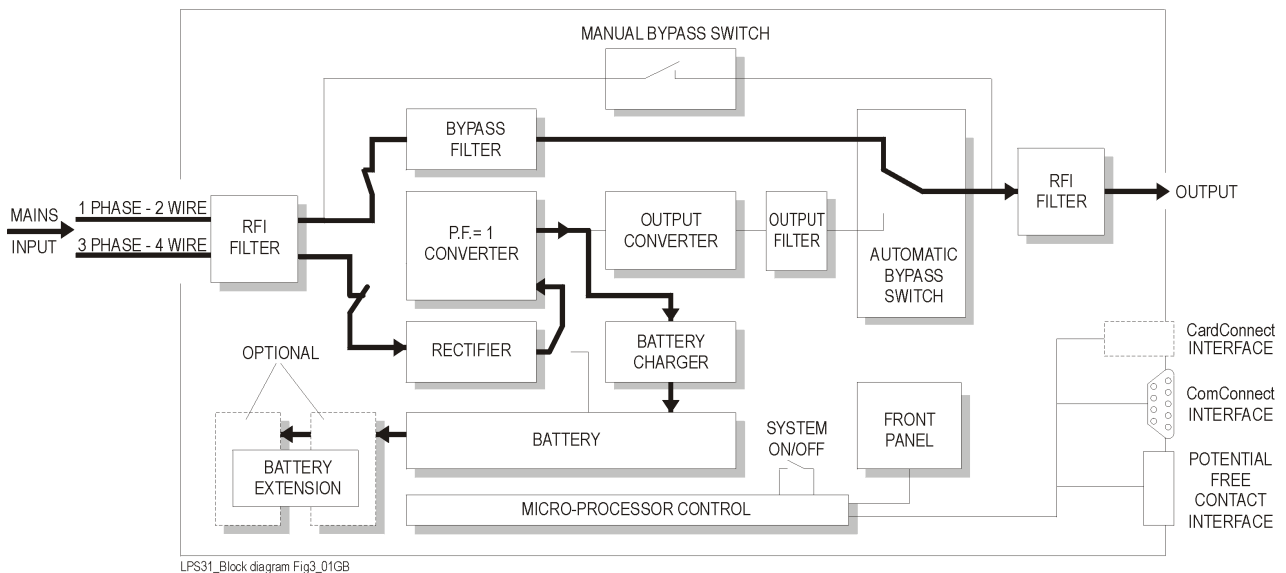

Figure 3 - Bypass operation

If a power failure occurs during bypass operation, load power is lost.

If the UPS functions under overload conditions it may not be able to protect the load.

3. EXTERNAL DESCRIPTION

3.1 Front and Rear Panel

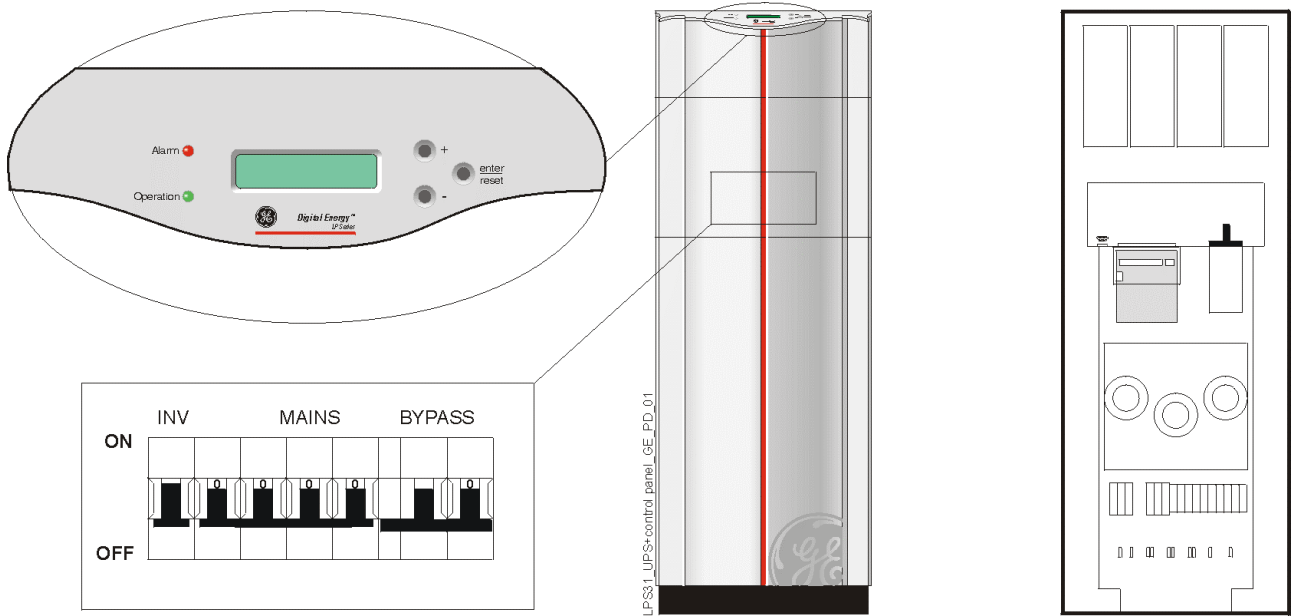

Figure 4 - Front and rear panel LP 31 Series / 8-10-15-20 kVA UPS

FRONT

- Operation/Alarm : green/red LED
- LCD screen: 2 x 16 characters
- Push-buttons: down/enter-reset/up
- Buzzer (resettable) Manual bypass switch
- Inverter on/off switch Input/Output terminals
- Mains fuse
- Bypass fuse

REAR

- Interfaces: - ComConnect (RS232)
- Potentialfree contacts
- CardConnect slot

3.2 The LCD screen

The LCD screen shows UPS system data, status messages, alarm messages, settings.

Six types of screens can be displayed:

- the default screen;
- information screens;
- setup screens;
- service screens;
- test screens.

The 'default screen' shows UPS model and actual load (values are examples):

LP 15-31
LOAD 37%

The 'information screens' show the UPSs system data:

- Mains voltage, mains frequency and the power delivered by the mains.
- Output voltage and output frequency, and the power delivered by the UPS.
- Power factor, crest factor and peak currents of the connected equipment.
- Temperature near the batteries, battery voltage and battery (dis)charging current.
- Remaining autonomy time (during mains failure).
- The total operating time of the UPS

The 'setup screens' show a programmable UPS function and its actual setting:

- System operating frequency.
- System operating voltage.
- Battery capacity.
- No-load shutdown (<2%).
- Bypass enable/disable.
- Frequency tracking range.

The 'service screens' show service information targeted on trained service personnel:

- Serial number of the UPS, release number of the installed software.
- Service information on internal components, fan speed, internal DC voltage, internal temperature levels, peak input voltage, mean (bypass) input voltage, mean output voltage.
- Start of a quick battery test.
- Forced (manual) transfer to bypass.

The 'test screens' show the proceeding of the following tests:

- General system test.
- Quick battery test.
- Battery calibration test.
- Bypass test.

3.3 Alarm Conditions

The LCD screen on the front panel displays status messages and alarm messages.

Three kinds of messages can be recognized.

- Status indications indicate the UPS operating mode.
- Low priority alarms indicate abnormal operating situations; the screen message is accompanied by a 1x per sec. blinking red LED and a 1x per 8 seconds. sounding buzzer, resettable.
- High priority alarms indicate situations in which the connected load is at risk as a *proper output voltage of the UPS is no longer guaranteed*; immediate action should be taken.
The screen message is accompanied by a 1x per sec. blinking red LED 'alarm' and a 1x per second sounding buzzer, resettable.

Note: By using ComConnect, additional conditions can be monitored and signals include written screen messages (see section 5, Interfacing).

4. STANDARD FEATURES

Automatic (quick) battery test

The *LP Series* family UPS conducts periodic automatic battery tests to ensure that the batteries and the wiring are healthy and able to support power failures.

The tests do not cause any interruption in the function of the unit.

Automatic tests are conducted after every 500 operating hours.

A manual battery test can be activated either through an interface kit via the ComConnect Port, or via the front panel.

Deep battery calibration test

The battery condition can be calibrated by the UPS monitoring software, ensuring accurate autonomy prediction.

Please refer to the manual of the appropriate monitoring software package for more information.

During a deep battery test the batteries will be discharged until 'battery low' alarm level.

The test will, after a complete recharge, result in new autonomy predictions.

Communications port

ComConnect: 9-pin Sub-D male plug

No-load shutdown

Whenever the load is <2% of the maximum load, and the input is absent for a period exceeding 10 minutes.

If the input voltage is restored, the output will be available again. Standard: activated.

Bypass enable/disable

If you do not want the automatic bypass switch to transfer to bypass, e.g. in situations of very bad or unstable mains, the bypass switch can be disabled.

Also if the unit is used as a frequency converter the bypass transfer must be disabled and the control knob of the manual bypass switch must be removed.

Frequency tracking range

The output frequency will follow the bypass frequency within the frequency tracking range (standard $\pm 2\%$).

If the bypass frequency is outside these limits, the inverter will run on its internal oscillator, and bypass transfer is inhibited.

If you want the bypass switch to operate over a wider frequency range (e.g. in case of generator supply), the tracking range can be changed into $\pm 4\%$ or $\pm 6\%$.

5. INTERFACING

5.1 ComConnect (RS232 Interface)

Located at the back of the unit, the ComConnect is a plug-in interface port (9-pin, Sub-D, male), which enables advanced communication between the UPS and the computer (interface kit required).

The microprocessor controlled and galvanically isolated ComConnect sends information concerning power levels and UPS condition to the computer or network interface.

In the event that batteries are near exhaustion, it sends commands for unattended controlled shutdown of computer systems.

The ComConnect can also receive UPS shutdown signals from computers or network interface.

When signals are sent to the computer, a written message can appear on the screen to inform the user.

Monitored conditions include:

- mains voltage availability;
- discharge level of batteries;
- temperature of the batteries;
- interactive control- and diagnostic information for stand-alone and network systems.

Interface kits (cables and software) are available for most commonly used network operating systems, including Novell, UNIX, VMS, Banyan Vines, Windows 3/95/98/NT, Apple, IBM LANserver, IBM AS/400.

Remote servicing through a modem (external) is possible with GE Victron SerVICe Software.

We strongly recommend to use only original GE software products in combination with the ComConnect interface port.

We only guarantee proper operation of original GE products.

The ComConnect cable should be shielded, connect the cable shield to the computer cabinet only.

For specific information on **GE** 's connectivity products please contact your dealer.

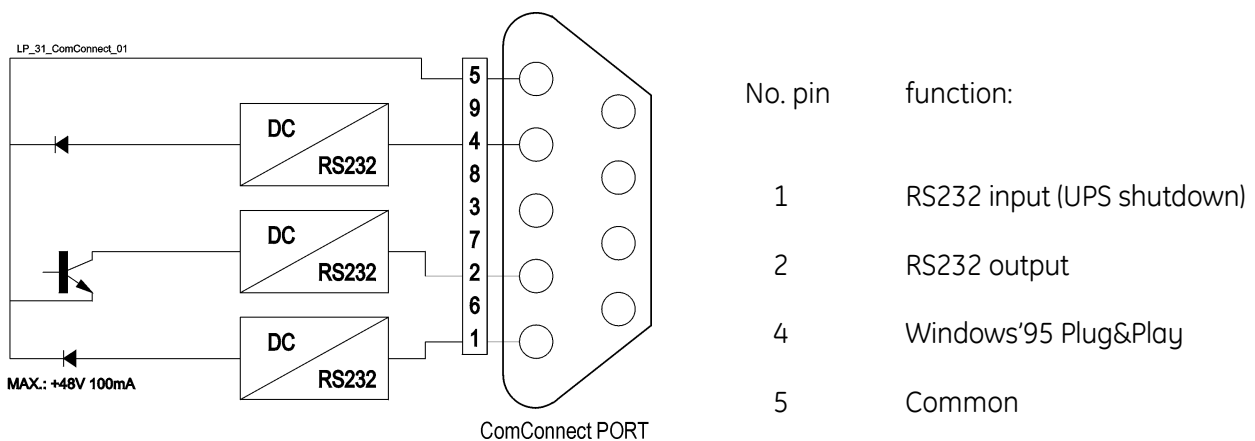

Figure 6 - ComConnect port

The ComConnect Port conforms to EN 50091 and is independent of the UPS function.

5.2 Potential Free Contact Interface

Four potential free change-over contacts are available for signalling the following alarms to a user defined system:

- bypass active;
- mains failure;
- battery low;
- general alarm.

Capacity of the relay contacts: Nom: 48V 500mA
 Min: 5V 100mA

5.3 SNMP Interface (optional)

The optional SNMP plug-in card allows the data interface to be connected directly to an Ethernet network.

6. OPTIONS

6.1 SNMP Interface Card

An SNMP interface card can be placed in the CardConnect slot at the rear panel of the UPS, and allows the data interface to be connected directly to an Ethernet network.

When this option is installed the ComProt communication link is no longer available to the user.

6.2 Alarm Boxes

An *interface box* linked to the ComConnect port, the VIC/RELAYBOX/01 translates the ComConnect signals to five independent changeover contacts, with a maximum switching capacity of 230V/5A each.

Wall mounted plastic *alarm boxes* are available for remote audible and visual alarm indication.

6.3 Connectivity Products

A *splitter box* translates information from the ComConnect to several computers.

Interface kits (cables and software) are available for UPS communication with most commonly used network operating systems, including Novell, UNIX, VMS, Banyan Vines, Windows 3-95-98-NT, Apple, 3COM, IBM LANserver, IBM AS/400.

Please contact your dealer for specific information.

6.4 Battery Extension Packs

Extended run-time versions are equipped with additional batteries to increase the autonomy time of the unit.

These additional batteries are housed in a separate battery cabinet and are connected in parallel. Additional batteries will increase the recharging time for the unit.