

MSR 4800W

Multi purpose Power System for Telecom and Industrial Applications



4800 W modular system

- All voltages available 0...144VDC per module
- U and I adjustable from 0 to max value
- Hot-swap plug-in modules
- Power supply or battery charging applications
- Module alarm for remote monitoring
- Solid construction for heavy duty applications

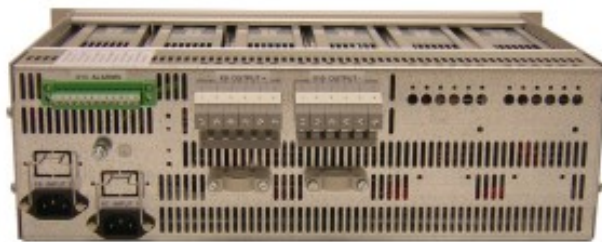

Flexible connections

- Parallel n+1 connection, up to 180A
- Series connection, up to 500VDC
- Multi outputs, \pm outputs
- Two separate inputs

Connection examples

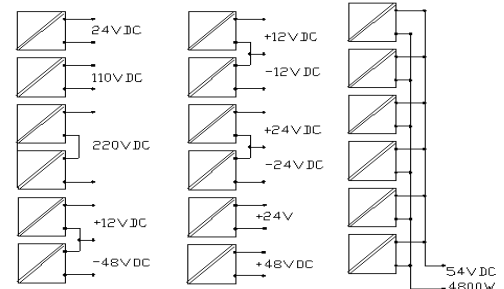

19" SUB-RACK UNITS			
Type	Modules per rack	Power	Mechanics (w x h x d)
MSR7650	1...6 pcs	800W...4800W	19" (482mm) / 3U (133mm) / 330mm (+handle 40mm)
8876500C	Covering plate set for empty module place		
70130753	IEC320 power cord 2.5m, rubber cable		

RECTIFIER MODULES							
Type	Input voltage *)	Nominal Output Voltage	Voltage Setting Range	Max Output Current	Current Limit Setting	Max Power	Mechanics (w x h x d)
ADC7181/24	55-264VAC/78-360VDC	24 VDC	0-36VDC	30 A	0-30A	800W	14TE / 3U / 230mm
ADC7181/36	55-264VAC/78-360VDC	36 VDC	0-54VDC	20 A	0-20A	800W	14TE / 3U / 230mm
ADC7181/48	55-264VAC/78-360VDC	48 VDC	0-72VDC	15 A	0-15A	800W	14TE / 3U / 230mm
ADC7181/72	55-264VAC/78-360VDC	72 VDC	0-108VDC	10 A	0-10A	800W	14TE / 3U / 230mm
ADC7181/96	55-264VAC/78-360VDC	96 VDC	0-144VDC	7.5A	0-7.5A	800W	14TE / 3U / 230mm

*) Max power 600W at DC input
Reduced power 55...200VAC or 78...200VDC



POWERNET



Sales & R&D: Mäkituvantie 3 H, FIN-01510 VANTAA, Tel. +358 9 8362 830, Fax +358 9 8362 8362
Production and Service: Teollisuuskatu 3, FIN-44150 ÄÄNEKOSKI, Tel. +358 14 3396 400, Fax +358 14 3396 410
E-mail: marketing@powernet.fi, service@powernet.fi, Internet: www.powernet.fi

INPUT

Input voltage	55...264 VAC 78...360 VDC / max 600W	55...200VAC reduced power, see module datasheet 78...200VDC reduced power, see module datasheet
Frequency		45...65Hz
Input current		Max 4.5A per module
Inrush current	Soft start	max 7A 10ms peak, otherwise less than 4.5A
Safety		According to EN60950, Class I
Isolation	Input / ground Input / outputs Output / ground	1500VAC 3750VAC 500VDC
Mains input connector	Common input 1 for unit 1, 2 and 3 Common input 2 for unit 4, 5 and 6 Located on rear panel	IEC320 C14 male connector (L-N-PE)

OUTPUT

Voltage	Nominal voltages	0...144VDC / max 800W per module
Current	Nominal current per module	0...30A / max 800W per module
Short circuit protection	The modules are short circuit protected	
Output connector	6 x positive and 6 x negative output group	10mm ² screw terminal for each rectifier short-circuit contact for parallel operation
Hot swap	Serial diode in each rectifier	Hot-swap allowed
Serial/parallel operations	All modules can be connected in series or in parallel	

ALARMS

Output failure	Module failure	Relay contact
Alarm connector	Rear panel Pin configurations	Removable 12-pole 2.5mm ² screw terminal
	<ul style="list-style-type: none"> 1 Output alarm PSU1 COMMON 2 Output alarm PSU1 NO *) 3 Output alarm PSU2 COMMON 4 Output alarm PSU2 NO *) 5 Output alarm PSU3 COMMON 6 Output alarm PSU3 NO *) 7 Output alarm PSU4 COMMON 8 Output alarm PSU4 NO *) 9 Output alarm PSU5 COMMON 10 Output alarm PSU5 NO *) 11 Output alarm PSU6 COMMON 12 Output alarm PSU6 NO *) 	<p>*) NO = Normally Open Normally = Mains / PSU OK</p> <p>NC contacts also available, type MSR7651</p>

MECHANICAL

Power Rack	19" sub-rack	Positions for 6 pcs of ADC7181 euro modules
Dimensions	Height	3U (88mm)
	Width	19" (482mm)
	Depth	330mm (+ handle 40mm)
Weight	Rack without rectifiers	4.0 kg
	Rectifier	1.35kg/unit
Enclosure	Steel	IP20

ENVIRONMENTAL

Temperature range	Operating	-25°C...+50 °C (full power typically) +50°C...+70 °C (derating)
	Storage	-40°C...+85 °C
Cooling	Temperature controlled fan	Front panel, air flow front to rear
Grounding	M6 screw	On the rear panel

Operating and connecting the sub-rack and modules

General

MSR7650 sub-rack can be used to supply several output voltages from 0V up to 500VDC in series connection. Modules can be connected in parallel, series or to have multi output voltages from the same sub-rack. Units are hot swappable, but the sub-rack also have both input and output switch to make the change without power. 1...6 pcs of modules can be installed in the sub-rack. Empty module places are covered by the cover plate.

Mounting the sub-rack

Sub-rack is installed in 19" cabinet and mounted by 4pcs of M6 screws from the front panel.

Mounting the plug-in module

The plug-in module is installed by pushing it to the bottom of sub-rack as long as the connector in the rear panel have the contact with the mating connector in sub-rack. Mounting screws in modules front panel are fastened. Removing the module is made in opposite order.

Mains connection

The mains is supplied by two IEC320 C14 male connectors. Use 1-phase power cords cross-section 3 x 1,5mm². The minimum mains fuse is 16A/mains cord. Make sure that both input and output are switched off in the sub-rack before connecting the mains. Turn the mains switch to up position. The unit is starting about 4 seconds. The unit's output led in front panel is lightning green.

Output connection

Use minimum 4mm² output cable, 6mm² preferred. Connect cables to the screw terminal in the sub-rack's rear panel via the cable clamp. Output MCBs can be turned to the ON position after module's output led in front panel is green.

Outputs can be in stand-alone, parallel or series use.

1. Stand alone use

Connect minimum 4mm² cables from modules + and - screw terminal to load.

2. Parallel use

Connect each module to the load by minimum 4mm² cables. To ensure proper load sharing the length and cross section of each output cable need to be the same and the output adjustment at each module should be equal.

3. Serial use

The serial connection is made by connecting the positive output of module 1 to the negative output of module 2 and connecting the load between the positive output of module 2 and negative output of module 1. Use minimum 4mm² cables.

Output voltage adjustment

The factory setting for the output is the nominal voltage (for example 48VDC). Output of each module can be adjusted by turning **Uadj** trimmer. The adjustment is made by small screw driver.

Output current limit adjustment

The factory setting for the current limit is the nominal output current. Output current limit (max current) can be adjusted from the **Iadj** trimmer.

Alarms

Module fail or output MCB fail

Each rectifier have module fail relay alarm NO and NC contact, but only NO contacts are available in standard sub-rack (separate rack with NC contacts). Alarms are wired to sub-rack rear panel, alarm screw terminal to pins 1-2, 3-4, 5-6, 7-8, 9-10 and 11-12. The cross section of alarm cable can be 0,22 ... 0,75mm². The status normal means the normal operating condition for the power supply. Alarms can be used separately from each rectifier or to be connected in parallel on rear connector X11.

Electrical connections in the sub-rack

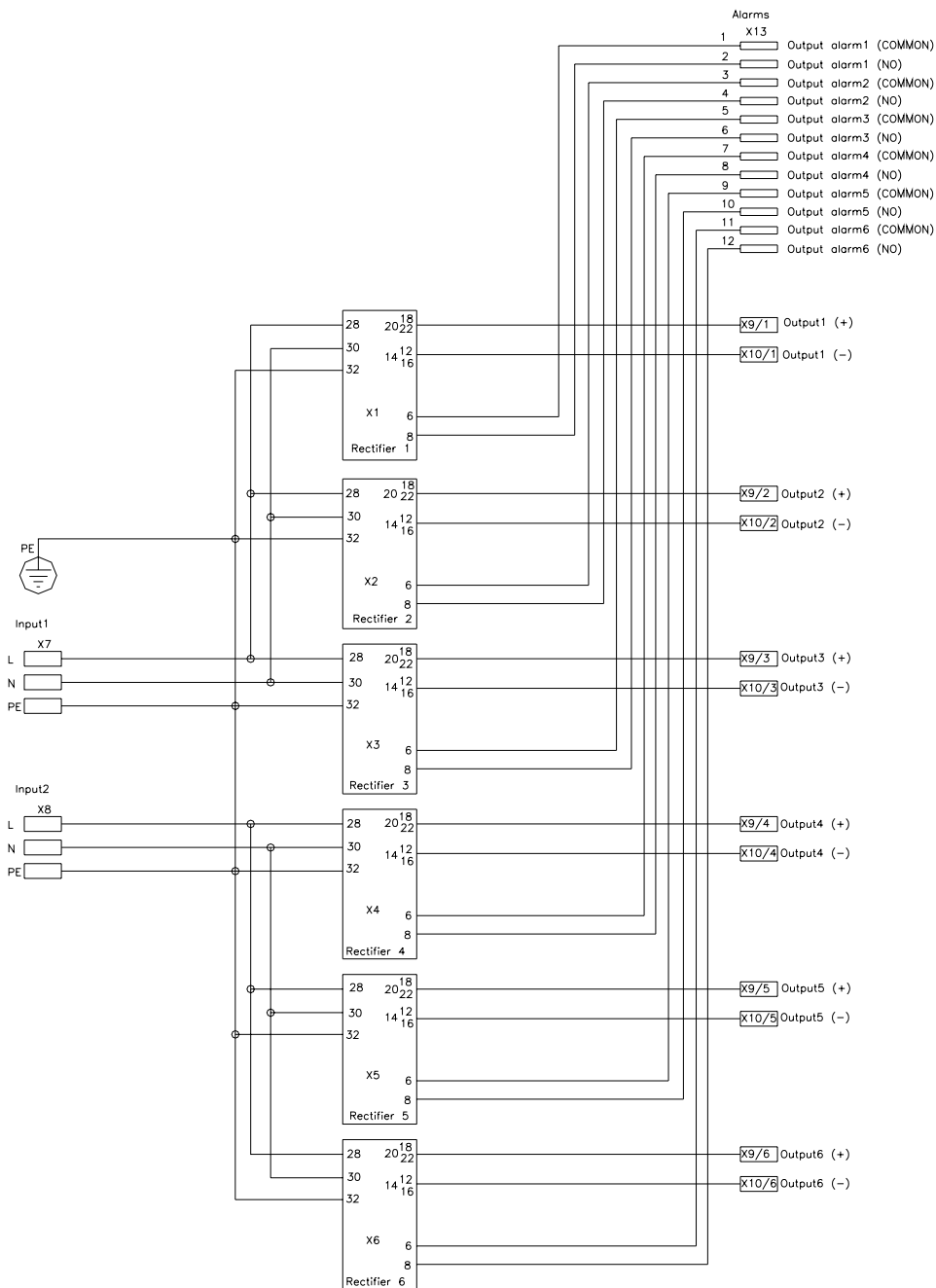

Pin Configuration in rear panel

Lead through position for analog control cable

